

امتحان دور مايو 2013
مادة كهربية وفيزياء حديثة

جامعة بنها
كلية العلوم
الفرقة الثانية تربية (تخلفات)
د./صلاح عيد ابراهيم حمزة
تاريخ الامتحان 2013/05/ 15

إجابة السؤال الأول

1. استنتج قانون توصيل ثلاث مكثفات تتوالي وتوازي مع الرسم.

(1) القانون المستخدم في حالة ثلاثة مكثفات موصلة علي التوالي هو

$$\frac{1}{C_t} = \frac{1}{C_1} + \frac{1}{C_2} + \frac{1}{C_3}$$

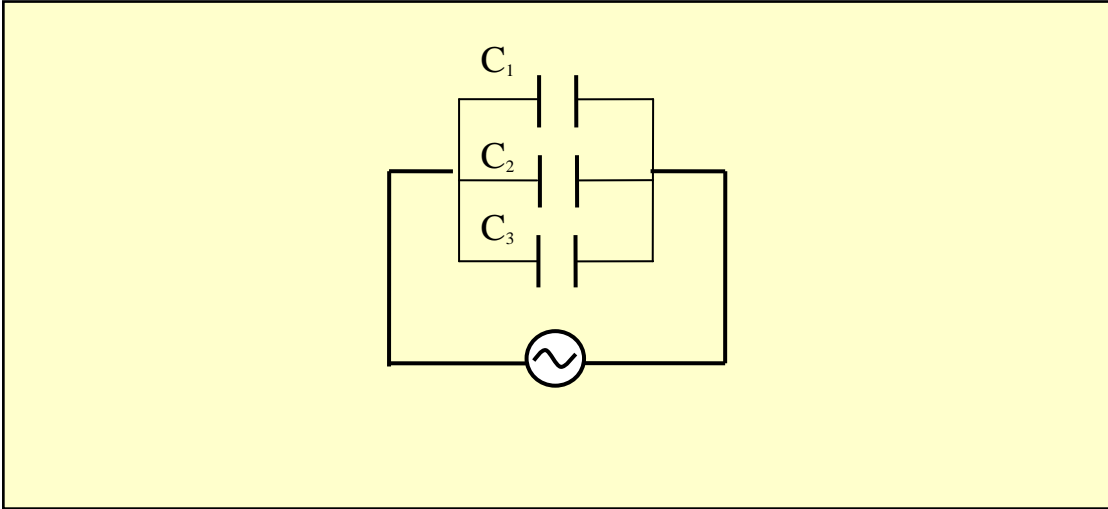

(2) القانون المستخدم في حالة ثلاثة مكثفات موصلة علي التوازي هو

$$C_t = C_1 + C_2 + C_3$$

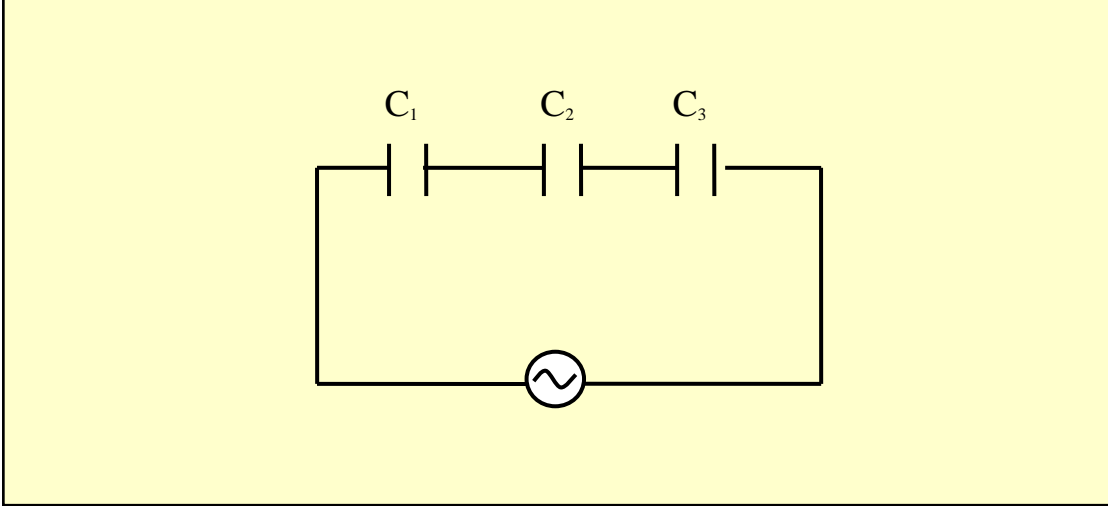

3. ينص قانون أوم علي أن شدة التيار I المار في مقاومة R يتناسب طرديا مع فرق الجهد V بين طرفيها

$$V \propto I$$

$$V = RI$$

(3) القانون المستخدم في حالة مقاومتين موصلتين علي التوازي هو

$$\frac{1}{R_t} = \frac{1}{R_1} + \frac{1}{R_2}$$

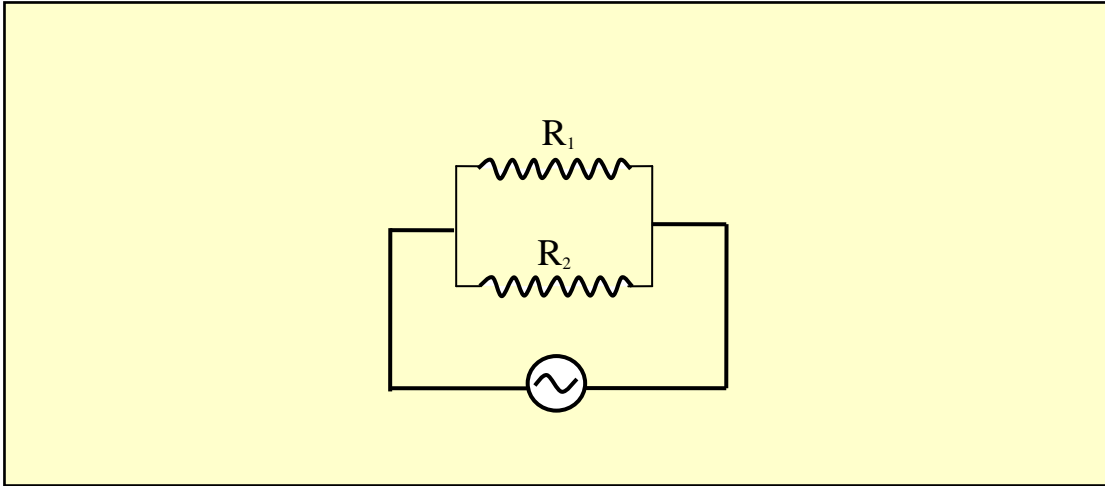

(4) القانون المستخدم في حالة توصيل مقاومتين علي التوالي هو

$$R_t = R_1 + R_2$$

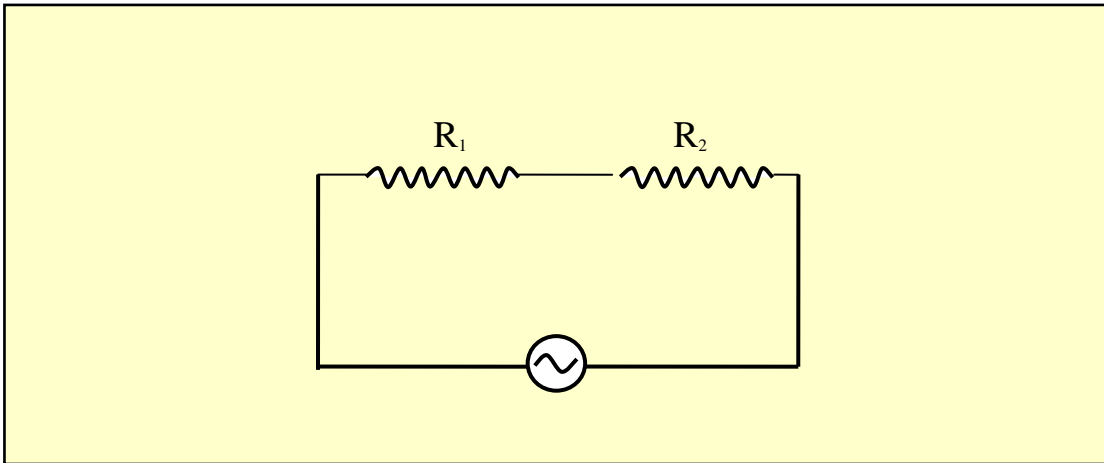

Radioactivity:

A sample containing a certain type of radioactive isotope tends to contain many such isotopes (perhaps on the order of *Avogadro's number* of such isotopes). Exactly *when* a particular isotope will undergo a radioactive decay is purely a matter of chance. (Remember, quantum mechanics only tells us *probabilities!*) Nevertheless, we can fairly accurately discuss *average* numbers of decays per second since we are dealing with such large numbers of isotopes and therefore such large numbers of decays.

Let $N(t)$ represent the number of radioactive parent isotopes in a given sample at the time t . As time goes on, the number of parent isotopes *decreases* since some of them will decay into *daughter* isotopes. Therefore, $N(t)$ is a *decreasing* function of time. It turns out that this function is an *exponentially decreasing* function of the form:

$$N(t) = N_0 e^{-\lambda t} \quad (10.13)$$

where N_0 is the number of radioactive parent isotopes that were present at the time $t = 0$, and λ is a constant called the **decay constant**. The units of λ are **1/s** (so that the quantity λt in the exponential is unitless). Each different isotope with its own radioactive decay will have its own characteristic value of λ corresponding to that particular decay.

The **activity**, **A**, of a radioactive sample is defined to be the number of radioactive decays (also called *disintegrations*) per second. (Note that the symbol A no longer means *mass number* in this discussion!) It can be shown (using calculus) that

$$A = \lambda N. \quad \text{Activity} \quad (10.14)$$

The *MKS* unit of activity is the *becquerel*, abbreviated *Bq*:

$$1 \text{ Bq} = 1 \frac{\text{disintegration}}{\text{second}} = 1 \frac{\text{dis}}{\text{s}}. \quad (10.15)$$

Another (*non-MKS!*) unit commonly encountered in the study of radioactive decay is the *curie*, abbreviated *Ci*:

$$1\text{Ci} = 3.7 \times 10^{10} \frac{\text{dis}}{\text{s}} = 3.7 \times 10^{10} \text{Bq}. \quad (10.16)$$

Since N in Eqs. (10.13) and (10.14) above is a function of time, it follows that A in Eq. (10.14) is also a function of time. (On the other hand, the value of the decay constant λ really *does* seem to be a constant for a given isotope—it does not seem to be affected by time, extreme temperature, pressure, *etc.*!) As the number of radioactive parent isotopes decreases, so the activity also decreases. The equation for A , Eq. (10.14), shows us that the number of disintegrations per second is proportional to the number of radioactive parent isotopes present at that time – something that should make sense to you if you think about it...

Note from Eqs. (10.13) and (10.14) above, that

$$A(t) = \lambda N(t) = \lambda N_0 e^{-\lambda t} \equiv A_0 e^{-\lambda t}, \quad (10.17)$$

where we have defined the **initial activity** of the sample (at time $t = 0$) to be $A_0 = \lambda N_0$. Eq. (10.17) is useful when we wish to compare activities at various times instead of numbers of nuclei (this is convenient since instruments such as **Geiger counters** measure *activities*).

It should be clear that, in order to be able to solve problems dealing with radioactive decay, you will have to be able to work with exponential functions and natural logarithms. Click on the [Math Review](#) button at the upper left if you wish to review some of the basic properties of these functions. The next two examples will demonstrate the use of some of these fundamental properties in solving radioactivity problems.